

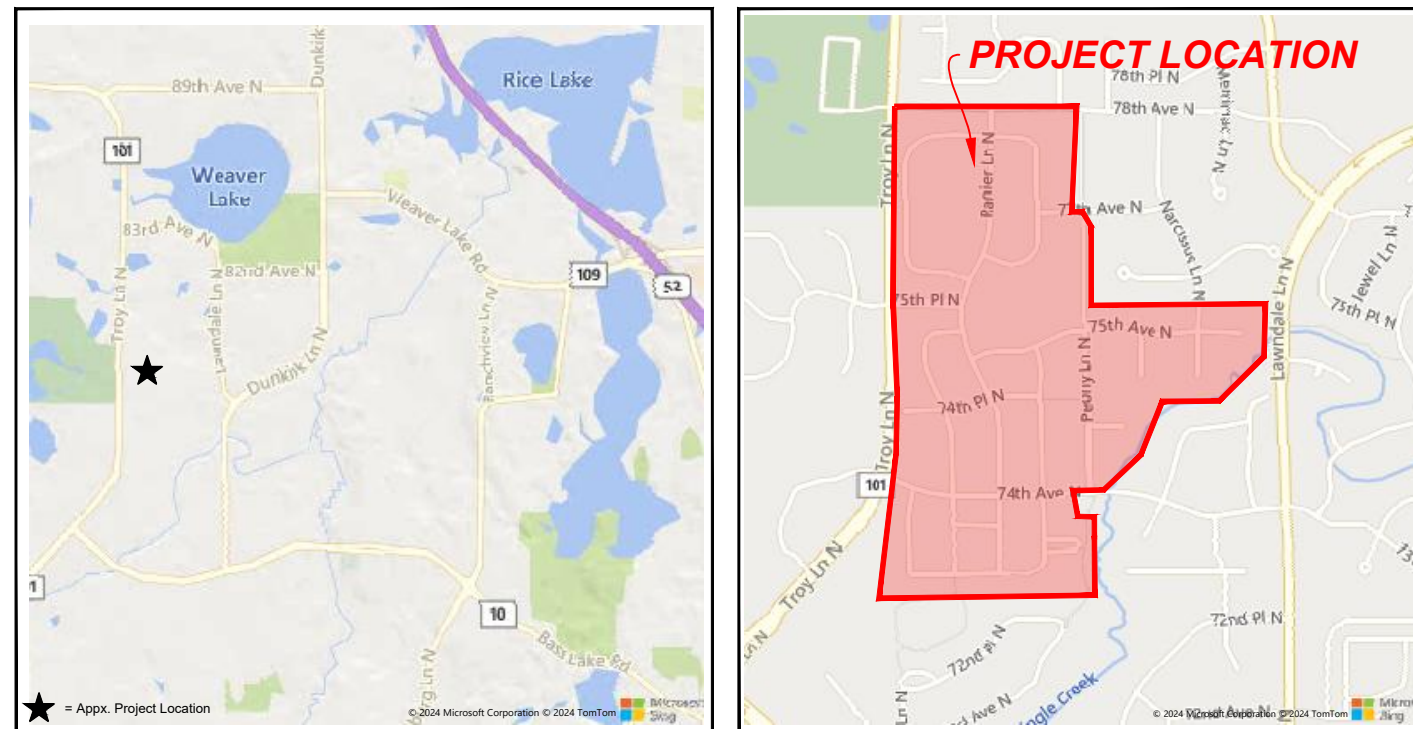

FIBERHOOD:
MPGV-MN-1-18

PROPOSED FIBER - OPTIC INSTALLATION - CIVIL DESIGN
75TH AVE N & RANIER LN N
MAPLE GROVE, MN

SITE LOCATION MAP



INDEX TO SHEETS

SHEETS	DESCRIPTION
A1-A3	TITLE SHEET & GENERAL NOTES
B1-B5	PROJECT PLAN VIEW
C1-C5	STANDARD CONSTRUCTION DETAILS

ENGINEER'S ESTIMATE OF MATERIALS (TOTAL)

QUANTITY	ITEM
22,296	LINEAR FEET OF DIRECTIONAL BORE

ENGINEER:
hbk
UTILITY
INFRASTRUCTURE
SOLUTIONS
ENGINEERING
A QUANTA SERVICES COMPANY
921 WEST VAN BUREN, SUITE 100
CHICAGO, IL 60607
PHONE: (312) 432-0076 FAX: (312) 432-0231
STATE OF ILLINOIS, DEPARTMENT OF PROFESSIONAL
REGULATION, LICENSE NO. 184-002308

OWNER/DEVELOPER:
gatewayfiber
275 WEST SERVICE RD
SUITE O
WRIGHT CITY, MO 63390

TITLE:
**PROPOSED FIBER - OPTIC
INSTALLATION - CIVIL DESIGN
75TH AVE N & RANIER LN N
MAPLE GROVE, MN**

REVISIONS

REV	DATE	DESCRIPTION	BY
00	12/30/24	FOR REVIEW	EJ
01			
02			
03			
04			
05			
06			
07			
08			
09			
10			
11			

DRAWN BY:	CHECKED BY:	APPROVED BY:
EJ	AJR	NFJ

PROJECT NUMBER: **24-0177**
DATE DRAWN: **12/30/24**

SHEET:
A1



NOTE: CONTRACTOR TO CONTACT
MINNESOTA 811 BEFORE DIGGING.
(1-800-252-1166)

GENERAL NOTES

DEVELOPER: GATEWAY FIBER
KIRK THOELKE
275 WEST SERVICE ROAD, STE O
WRIGHT CITY, MO 63390
KIRK.THUOLKE@GATEWAYFIBER.COM

PROJECT MANAGER: HBK ENGINEERING, LLC
NICK FREERKS
509 S. GILBERT ST.
IOWA CITY, IA 52240
(319) 338-7557
NRFREERKS@HBKENGINEERING.COM

SECTION 1.0 SCOPE OF WORK

- CONSTRUCTION OF ALL RELATED APPURTENANCES FOR FIBER OPTIC CABLE INSTALLATION. SEE PLANS FOR EXACT LOCATION, LENGTHS, QUANTITIES, AND DIMENSIONS OF PROPOSED IMPROVEMENTS.
- THE CONTRACTOR SHALL PROVIDE ALL MATERIAL, EQUIPMENT, LABOR, INSTALLATION, RESTORATION, UTILITY RELOCATION CHARGES, JOB SITE DELIVERY COSTS TO COMPLETE THE DESCRIBED, OR ILLUSTRATED WORK, UNDER THIS CONTRACT.
- ANY CHANGE-ORDER REQUEST MUST BE PRESENTED IN WRITING TO THE OWNER'S REPRESENTATIVE; AND APPROVED PRIOR TO PROCEEDING WITH THE REQUESTED CHANGE. DOCUMENTATION CONCERNING ANY AND ALL CHANGE ORDERS WILL BE REDUCED TO FORMAL RECORD, FILED WITH THE OWNER'S REPRESENTATIVE, AND BE MADE AVAILABLE FOR FUTURE REFERENCE.
- THE ENGINEER WILL NOT BE RESPONSIBLE NOR ASSUME ANY LIABILITY FOR NEGLIGENT ACTS OR ERRORS OF OMISSIONS OF ANY CONTRACTOR, ANY SUBCONTRACTOR, OR ANY OF THE CONTRACTOR'S OR SUBCONTRACTORS' AGENTS OR EMPLOYEES OR ANY OTHER PERSONS (EXCEPT ENGINEER'S OWN EMPLOYEES) AT THE PROJECT SITE OR OTHERWISE PERFORMING ANY OF THE WORK OF THE PROJECT. ANY CONTRACTOR OR SUB-CONTRACTOR, AS WELL AS THE ENGINEER, WILL BE RESPONSIBLE FOR THEIR OWN SAFETY PROGRAM. NEITHER THE PROFESSIONAL ACTIVITIES OF THE ENGINEER, NOR THE PRESENCE OF THE ENGINEER OR THEIR EMPLOYEES AND SUBCONSULTANTS AT THE CONSTRUCTION SITE, SHALL RELIEVE ANY CONTRACTOR OF THEIR OBLIGATIONS, DUTIES AND RESPONSIBILITIES INCLUDING, BUT NOT LIMITED TO, CONSTRUCTION MEANS, METHODS, SEQUENCE, TECHNIQUES OR PROCEDURES NECESSARY FOR PERFORMING, SUPERINTENDING OR COORDINATING ALL PORTIONS OF THE WORK OF CONSTRUCTION IN ACCORDANCE WITH THE CONTRACT DOCUMENTS AND ANY HEALTH OR SAFETY PRECAUTIONS REQUIRED BY ANY REGULATORY AGENCIES. THE ENGINEER AND THEIR PERSONNEL HAVE NO AUTHORITY TO EXERCISE ANY CONTROL OVER ANY CONSTRUCTION CONTRACTOR OR OTHER ENTITY OR THEIR EMPLOYEES IN CONNECTION WITH ANY HEALTH OR SAFETY PRECAUTIONS.

SECTION 2.0 MATERIALS

- ALL MATERIALS INSTALLED WITHIN THE LIMITS OF THIS PROJECT SHALL BE IN CONFORMANCE WITH STANDARD RECOMMENDATIONS OF THE NATIONAL ELECTRICAL MANUFACTURER'S ASSOCIATION AND AMERICAN NATIONAL STANDARDS INSTITUTE.
- JOB SITE MATERIAL WILL BE DELIVERED TO, AND MAINTAINED AT THE STREET WORK AREAS IN A WELL MANAGED MANNER, TO MINIMIZE CONGESTION OR INCONVENIENCE TO OTHER WORKERS, OR CONTRACTORS WORKING UNDER ALTERNATE PERMITS.

SECTION 3.0 GENERAL NOTES

- THESE NOTES SHALL BE CONSIDERED A PART OF THE WRITTEN SPECIFICATIONS.
- THE WORK SHALL INCLUDE FURNISHING MATERIALS, EQUIPMENT, APPURTENANCES AND LABOR NECESSARY TO COMPLETE ALL INSTALLATIONS AS INDICATED ON THE DRAWINGS.
- PRIOR TO THE SUBMISSION OF BIDS, THE CONTRACTORS SHALL VISIT THE JOB SITE AND BE RESPONSIBLE FOR ALL CONTRACT DOCUMENTS, FIELD CONDITIONS AND DIMENSIONS, AND CONFIRMING THAT THE WORK MAY BE ACCOMPLISHED AS SHOWN PRIOR TO PROCEEDING WITH CONSTRUCTION. ANY DISCREPANCIES ARE TO BE BROUGHT TO THE ATTENTION OF THE IMPLEMENTATION ENGINEER AND ARCHITECT/ENGINEER PRIOR TO PROCEEDING WITH THE WORK.
- THE CONTRACTOR SHALL RECEIVE, IN WRITING, AUTHORIZATION TO PROCEED BEFORE STARTING WORK ON ANY ITEM NOT CLEARLY DEFINED OR IDENTIFIED BY THE CONTRACT DOCUMENTS.
- THE CONTRACTOR SHALL INSTALL ALL EQUIPMENT AND MATERIALS IN ACCORDANCE WITH MANUFACTURER'S RECOMMENDATIONS UNLESS SPECIFICALLY INDICATED OTHERWISE OR WHERE LOCAL CODES OR REGULATIONS TAKE PRECEDENCE.
- ALL WORK PERFORMED AND MATERIALS INSTALLED SHALL BE IN STRICT ACCORDANCE WITH ALL APPLICABLE CODES, REGULATIONS AND ORDINANCES. CONTRACTOR SHALL GIVE ALL NOTICES AND COMPLY WITH ALL LAWS, ORDINANCES, RULES, REGULATIONS AND LAWFUL ORDERS OF ANY PUBLIC AUTHORITY REGARDING THE PERFORMANCE OF THE WORK. MECHANICAL AND ELECTRICAL SYSTEMS SHALL BE INSTALLED IN ACCORDANCE WITH ALL APPLICABLE MUNICIPAL AND UTILITY COMPANY SPECIFICATIONS, AND LOCAL AND STATE JURISDICTIONAL CODES, ORDINANCES AND APPLICABLE REGULATIONS.

- THE GENERAL CONTRACTOR SHALL SUPERVISE AND DIRECT THE WORK, USING THE BEST SKILLS AND ATTENTION. THE CONTRACTOR SHALL BE SOLELY RESPONSIBLE FOR ALL CONSTRUCTIONS MEANS, METHODS, TECHNIQUES, SEQUENCES AND PROCEDURES AND FOR COORDINATION ALL PORTION OF THE WORK UNDER THE CONTRACT INCLUDING CONTACT AND COORDINATION WITH THE IMPLEMENTATION ENGINEER AND WITH THE LANDLORD'S AUTHORIZED REPRESENTATIVE.
- SEAL PENETRATIONS THROUGH FIRE RATED AREAS WITH U.L. LISTED FIRE CODE APPROVED MATERIALS
- PROVIDE A PORTABLE FIRE EXTINGUISHER WITH A RATING OF NOT LESS THAN 2-A OR 2-A10BC WITHIN 75 FEET TRAVEL DISTANCE TO ALL PORTIONS OF THE PROJECT AREA DURING CONSTRUCTION.
- DETAILS ARE INTENDED TO SHOW END RESULTS OF DESIGN. MINOR MODIFICATIONS MAY BE REQUIRED TO SUITE JOB DIMENSIONS OR CONDITIONS, AND SUCH MODIFICATIONS SHALL BE INCLUDED AS PART OF THE WORK.
- THE CONTRACTOR SHALL MAKE NECESSARY PROVISIONS TO PROTECT EXISTING IMPROVEMENTS, PAVING, CURBS, VEGETATION, GALVANIZED SURFACE, ETC., AND UPON COMPLETION OF WORK REPAIR ANY DAMAGE THAT OCCURRED DURING CONSTRUCTION TO THE SATISFACTION OF OWNER/DEVELOPER AND AFFECTED PROPERTY OWNER.
- KEEP GENERAL AREA CLEAN, HAZARD FREE, AND DISPOSE OF ALL DIRT, DEBRIS, RUBBISH AND REMOVE EQUIPMENT NOT SPECIFIED AS REMAINING ON THE PROPERTY. LEAVE PREMISES IN CLEAN CONDITION AND FREE FROM PAINT SPOTS, DUST OR SMUDGES OF ANY NATURE.
- REPRESENTATIONS OF TRUE NORTH, OTHER THAN THOSE FOUND ON THE PLOT OF SURVEY DRAWING, SHALL NOT BE USED TO IDENTIFY OR ESTABLISH THE BEARING OF TRUE NORTH AT THE SITE. THE CONTRACTOR SHALL RELY SOLELY ON THE PLAT OF SURVEY DRAWING AND ANY SURVEYOR'S MARKINGS AT THE SITE FOR THE ESTABLISHMENT OF TRUE NORTH, AND SHALL NOTIFY THE ARCHITECT/ENGINEER PRIOR TO PROCEEDING WITH THE WORK. IF ANY DISCREPANCY IS FOUND BETWEEN THE VARIOUS ELEMENTS OF THE WORKING DRAWINGS AND THE TRUE NORTH ORIENTATION AS DEPICTED ON THE CIVIL SURVEY, THE CONTRACTOR SHALL ASSUME SOLE LIABILITY FOR ANY FAILURE TO NOTIFY THE ARCHITECT/ENGINEER.
- PENETRATIONS OF ROOF MEMBRANES SHALL BE PATCHED/FLASHED AND MADE WATERTIGHT USING LIKE MATERIALS IN ACCORDANCE WITH NRCA ROOFING STANDARDS AND DETAILS. CONTRACTOR SHALL OBTAIN DETAILING CLARIFICATION FOR SITE-SPECIFIC CONDITIONS FROM ARCHITECT/ENGINEER, IF NECESSARY, BEFORE PROCEEDING. PLANS ARE NOT TO BE SCALED AND ARE INTENDED TO BE A DIAGRAMMATIC OUTLINE ONLY, UNLESS NOTED OTHERWISE.
- PLANS ARE NOT TO BE SCALED AND ARE INTENDED TO BE DIAGRAMMATIC OUTLINE ONLY, UNLESS NOTED OTHERWISE.
- DIMENSIONS SHALL TAKE PRECEDENCE OVER SCALES SHOWN ON THE DRAWING. DIMENSIONS SHOW ARE ESTIMATED AND SHALL BE VERIFIED BY A SURVEYOR OR BY THE CONTRACTOR PRIOR TO CONSTRUCTION.
- ALL SITE WORK SHALL BE CAREFULLY COORDINATED BY GENERAL CONTRACTOR WITH LOCAL UTILITY COMPANY, TELEPHONE COMPANY, AND ANY OTHER UTILITY COMPANIES HAVING JURISDICTION OVER THIS LOCATION.
- CONTRACTOR IS ADVISED TO READ ALL NOTES ON DRAWINGS, CAREFULLY.
- CONTRACTOR TO FIELD VERIFY LOCATIONS OF ALL OVERHEAD OBSTRUCTIONS PRIOR TO COMMENCEMENT OF WORK.
- THE CONTRACTOR SHALL CONTACT 811 AT 800-252-1166 TO REQUEST LOCATING AND MARKING OF EXISTING UTILITIES PRIOR TO PERFORMING ANY EXCAVATION WORK IN OR AROUND ANY UTILITY. THE CONTRACTOR SHALL OBTAIN ALL PERMITS FOR THE INSTALLATION OF THE NEW UTILITIES AND SHALL COMPLY WITH ALL REQUIREMENTS OF ALL AGENCIES HAVING JURISDICTION OVER THE WORK.
- THE CONTRACTOR SHALL VERIFY EXISTING STREET RIGHTS OF WAY TO THE EXTENT NECESSARY TO VERIFY PROPOSED WORK REMAINS WITHIN THESE RIGHTS OF WAY AND DOES NOT INFRINGE ONTO PRIVATE PROPERTY NOT OWNED BY THE OWNER.
- ALL DISCREPANCIES SHOULD BE REPORTED TO HBK ENGINEERING, LLC AT 312-432-0076. ANY QUESTIONS OR COMMENTS THE CONTRACTOR MAY HAVE ARE TO BE DISCUSSED WITH THE OWNER AND ENGINEER PRIOR TO CONSTRUCTION COMMENTS.
- FURTHER, THE CONTRACTOR SHALL RECORD THE LOCATION/ELEVATION OF ALL UTILITIES ENCOUNTERED AND NEW INSTALLATIONS AS THE WORK PROGRESSES. CONTRACTOR TO PREPARE RECORD DRAWINGS (RED-LINES) BASED ON THEIR RECORDS. THESE RECORDS TO BE SUPPLIED TO HBK ENGINEERING, LLC AND GATEWAY AT COMPLETION OF WORK.
- SCALE FOR DRAWINGS IS FOR GENERAL INFORMATION ONLY. LOCATIONS AND DIMENSIONS SHALL BE TAKEN AS SHOWN AND THE DRAWINGS SHALL NOT BE SCALED.
- THE CONTRACTOR SHALL HAVE ALL PERMITS ONSITE AND COMPLY WITH THE REQUIREMENTS OF ALL AGENCIES HAVING JURISDICTION OVER THE WORK AND SHALL COORDINATE THEIR WORK WITH THE WORK PERFORMED BY OTHERS.
- CONTRACTOR SHALL COORDINATE ALL WORK WITH ALL PUBLIC AND PRIVATE UTILITIES AS WELL AS CITY AND STATE AGENCIES.
- CONTRACTOR SHALL TAKE ALL NECESSARY SAFETY PRECAUTIONS TO PROTECT UTILITIES, PEDESTRIANS, WORKERS AND VEHICULAR TRAFFIC. THE CONTRACTOR SHALL PROVIDE TEMPORARY FENCES, BARRICADES, ETC. AS REQUIRED TO PROTECT ADJACENT PROPERTY AND THE PUBLIC DURING ALL PHASES OF CONSTRUCTION.
- THE CONTRACTOR SHALL INSTALL AND DESIGN WOODEN PASSAGEWAYS TO DIVERT THE GENERAL PUBLIC AROUND THE CONSTRUCTION SITE IN A SAFE AND ORDERLY MANNER, AS REQUIRED.
- NO STORAGE OF EQUIPMENT OR MATERIALS IN THE ROADWAY IS PERMITTED UNLESS THE CONTRACTOR OBTAINS WRITTEN PERMISSION FROM THE CITY, STATE, AND/OR GOVERNING BODY.

- CONTRACTOR SHALL ASSUME ALL CABLES ARE ENERGIZED AND SHALL BE SUPPORTED SO AS NOT TO STRESS ANY PORTION OF THE CABLE.
- CONTRACTOR IS RESPONSIBLE FOR OBTAINING AND PROVIDING REVIEW AND DESIGN OF ANY AND ALL TEMPORARY UTILITY SUPPORT SYSTEMS PRIOR TO CONSTRUCTION.
- CONTRACTOR TO TREE TRIM AS NECESSARY AROUND POLES.
- MAKE READY INDICATES EXISTING FIBER CABLES NEED ADJUSTMENTS IN ORDER FOR NEW FIBER CABLE TO MEET REQUIRED CODES OR CLEARANCES.
- INSTALL A 50' SLACK MAINTENANCE LOOP EVERY 1000' AT STRATEGIC LOCATIONS TO BE DETERMINED IN THE FIELD PRIORITIZING LOCATIONS NEAR MAJOR ROAD CROSSING, WATERWAYS AND RAILROAD CROSSINGS.
- CONTRACTOR TO INSTALL FIBER IN GENERAL UTILITY EASEMENTS ONLY. FIBER LINES MAY CROSS, BUT NO STRUCTURES TO BE PLACED WITHIN SANITARY SEWER, GAS PIPELINE, WATER, DRAINAGE, OR MUTUAL ACCESS EASEMENTS.
- OUTDOOR CABINETS SHALL BE GROUNDED PER THE MANUFACTURER'S RECOMMENDATIONS AND PER ANSI/TIA-607B OR LATEST STANDARD.
- CONTRACTOR TO REFERENCE GATEWAY FIBER OPERATIONS HANDBOOK MOST RECENT REVISION FOR CONSTRUCTION SPECIFICATIONS.
- THE CONTRACTOR SHALL FIELD VERIFY EXISTING UTILITIES IN THE FIELD AND CALL 811 PRIOR TO PERFORMING ANY WORK.
- EXISTING UTILITIES SHOWN REPRESENT ASCE QUALITY LEVEL D STANDARDS BASED ON AVAILABLE ATLAS DATA AT THE TIME.
- FLOWER POT LOCATIONS SHOWN IN PRIVATE PROPERTY FOR CONTRACTOR REFERENCE ONLY. NO INSTALLATIONS ARE TO OCCUR WITHIN PRIVATE PROPERTY.

FIBERHOOD:
MPGV-MN-1-18

ENGINEER:



hbK
ENGINEERING
A QUANTA SERVICES COMPANY

921 WEST VAN BUREN, SUITE 100
CHICAGO, IL 60607
PHONE: (312) 432-0076 FAX: (312) 432-0231
STATE OF ILLINOIS DEPARTMENT OF PROFESSIONAL
REGULATION, LICENSE NO. 184-002308

OWNER/DEVELOPER:



gatewayfiber

275 WEST SERVICE RD
SUITE O
WRIGHT CITY, MO 63390

TITLE:
**PROPOSED FIBER - OPTIC
INSTALLATION - CIVIL DESIGN
75TH AVE N & RANIER LN N
MAPLE GROVE, MN**

REVISIONS			
REV	DATE	DESCRIPTION	BY
00	12/30/24	FOR REVIEW	EJ
01			
02			
03			
04			
05			
06			
07			
08			
09			
10			
11			

DRAWN BY:	CHECKED BY:	APPROVED BY:
EJ	AJR	NFJ

PROJECT NUMBER:	24-0177
DATE DRAWN:	12/30/24

SHEET:
A2

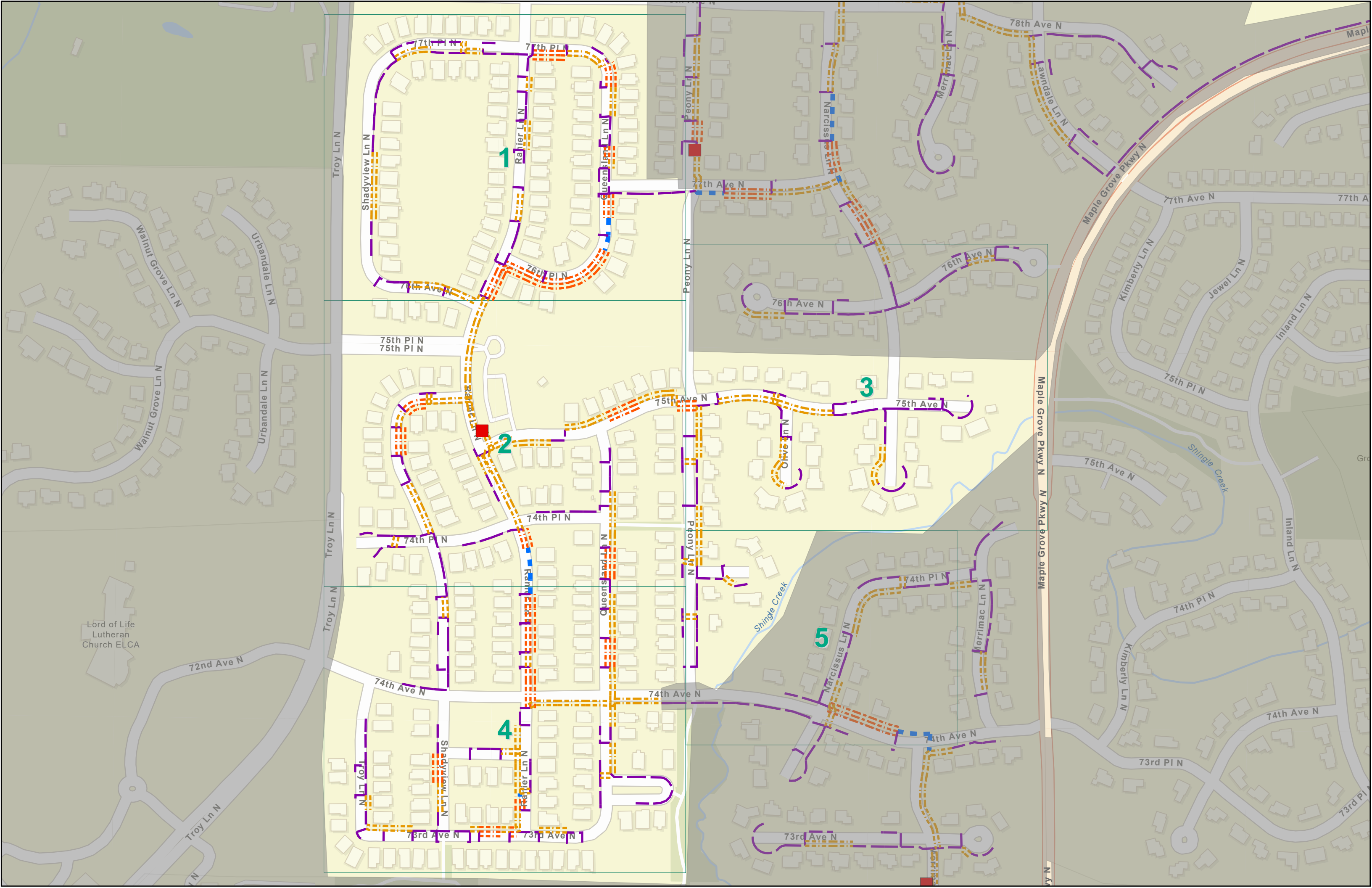

1

2

3

4

5

Lord of Life
Lutheran
Church ELCA

Troy Ln N

Troy Ln N

Troy Ln N

Troy Ln N

77th Pl N

75th Pl N

74th Pl N

74th Ave N

73rd Ave N

77th Pl N

76th Pl N

74th Pl N

74th Ave N

73rd Ave N

Rahier Ln N

Queensland Ln N

Rahier Ln N

Peony Ln N

Peony Ln N

75th Ave N

Peony Ln N

74th Ave N

Shingle Creek

Narcissus Ln N

Orchard Ln N

Narcissus Ln N

73rd Ave N

Merrimac Ln N

76th Ave N

74th Pl N

74th Ave N

78th Ave N

77th Ave N

76th Ave N

75th Ave N

75th Ave N

Maple Grove Pkwy N

74th Ave N

73rd Pl N

73rd Pl N

Kimberly Ln N

75th Ave N

Kimberly Ln N

73rd Pl N

77th Ave N

75th Pl N

74th Pl N

73rd Pl N

Jewel Ln N

Shingle Creek

Kimberly Ln N

74th Ave N

Inland Ln N

Inland Ln N

74th Ave N

73rd Pl N

77th Ave N

75th Pl N

74th Pl N

73rd Pl N

Legend

- Parcels - Hennepin County
- Cabinet
- Civil Structures**
 - FlowerPot
 - Handhole
- Civil Pathway**
 - Proposed, BM60(1) (1.25)
 - Proposed, BM60(2) (1.25)
 - Proposed, BM60(3) (1.25)
 - Proposed, BM60(4) (1.25)
- irrConduit
- irrCurbStop
- irrHandholes
- irrHeads
- irrPipes
- irrValves
- ssManhole
- ssNetworkStructure
- ssPipes
- ssPipes_Retired
- swPipes
- swManhole
- swInlet
- swControlValves
- swDrainTile
- swDrainTileStructures
- swNetworkStructure
- swOutlet
- wHydrant
- wPipes
- wSystemValve
- wControlValve
- Reference Only Duct
- wMeter_Irrigation

Address - For Printing Only

Address - For Printing Only

MapleGrove Reference Duct

- Reference Only Duct
- wMeter_Irrigation

Scale: 1" = 100 ft

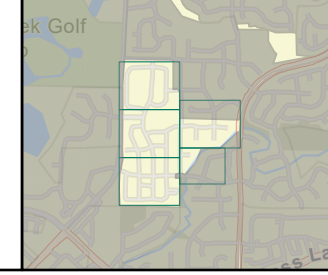

SHADED AREA TO BE PERMITTED UNDER SEPERATE COVER

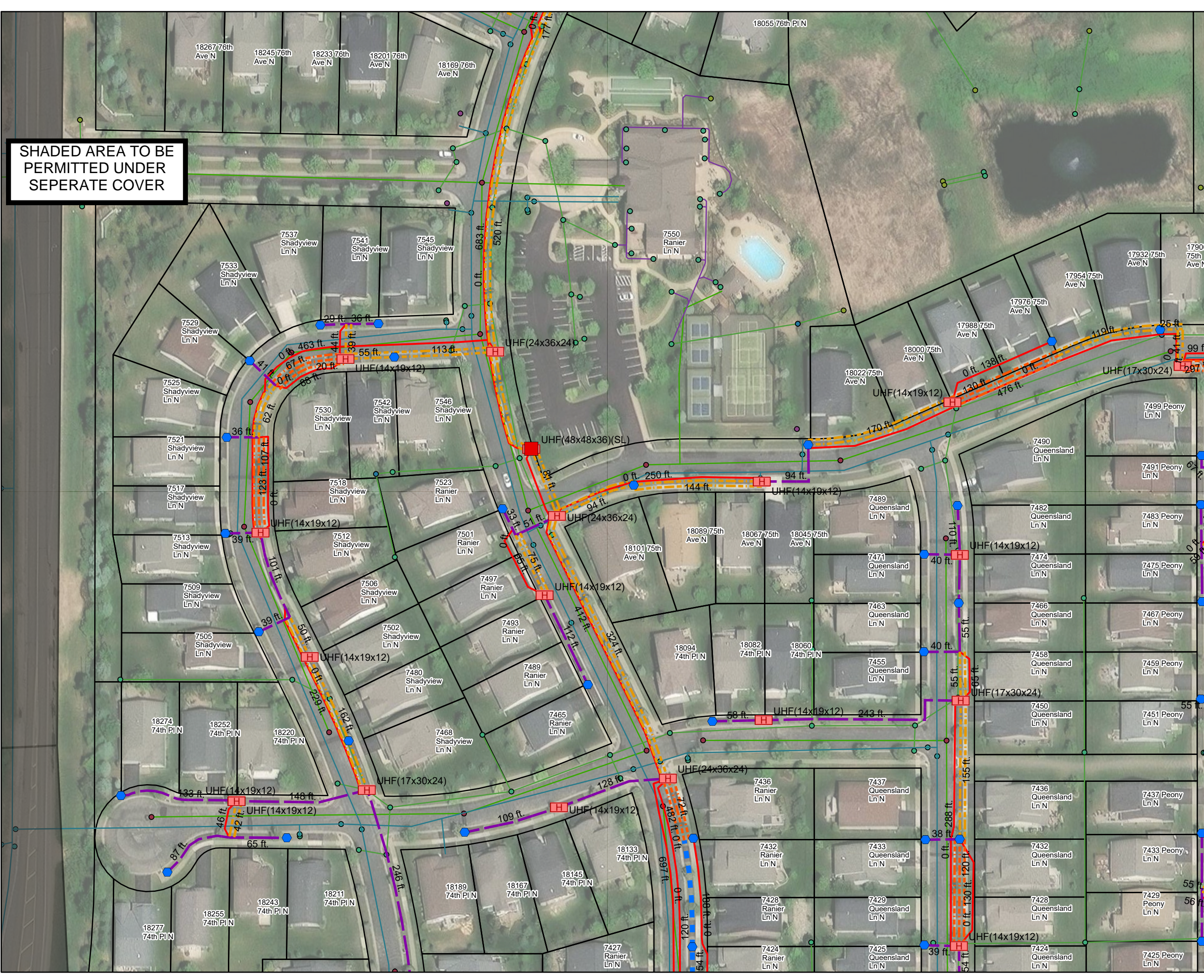

SHADED AREA TO BE PERMITTED UNDER SEPERATE COVER

Legend

- Parcels - Hennepin County
- FlowerPot
- Handhole
- Proposed, BM60(1) (1.25)
- Proposed, BM60(2) (1.25)
- Proposed, BM60(3) (1.25)
- Reference Only Duct
- wMeter_Irrigation
- irrcConduit
- irrcurbStop
- irrcHandholes
- irrcHeads
- irrcPipes
- irrcValves
- ssManhole
- ssNetworkStructure
- ssPipes
- ssPipes_Retired
- swPipes
- swManhole
- swInlet
- swControlValves
- swDrainTile
- swDrainTileStructures
- swNetworkStructure
- swOutlet
- wHydrant
- wPipes
- wSystemValve
- wControlValve

Address - For Printing Only

Address - For Printing Only

MapleGrove Reference Duct

Scale: 1" = 100 ft

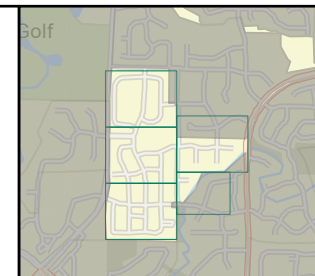

SHADED AREA TO BE PERMITTED UNDER SEPERATE COVER

SHADED AREA TO BE PERMITTED UNDER SEPERATE COVER

HBK Engineering
 Sheet: B4 of B5
 County: Hennepin
 MPG-V-MN-01-18
 As of: 12/31/2024

Legend

Parcels - Hennepin County	irrConduit
Civil Structures	irrCurbStop
FlowerPot	irrHandholes
Handhole	irrHeads
Civil Pathway	irrPipes
Proposed, BM60(1) (1.25)	irrValves
Proposed, BM60(2) (1.25)	ssManhole
Proposed, BM60(3) (1.25)	ssNetworkStructure
Proposed, BM60(4) (1.25)	ssPipes
	ssPipes_Retired
	swPipes
	swManhole
	swInlet
	swControlValves
Address - For Printing Only	swDrainTile
Address - For Printing Only	swDrainTileStructures
MapleGrove Reference Duct	swNetworkStructure
Reference Only Duct	swOutlet
wMeter_Irrigation	wHydrant
	wPipes
	wSystemValve
	wControlValve

Scale: 1" = 100 ft

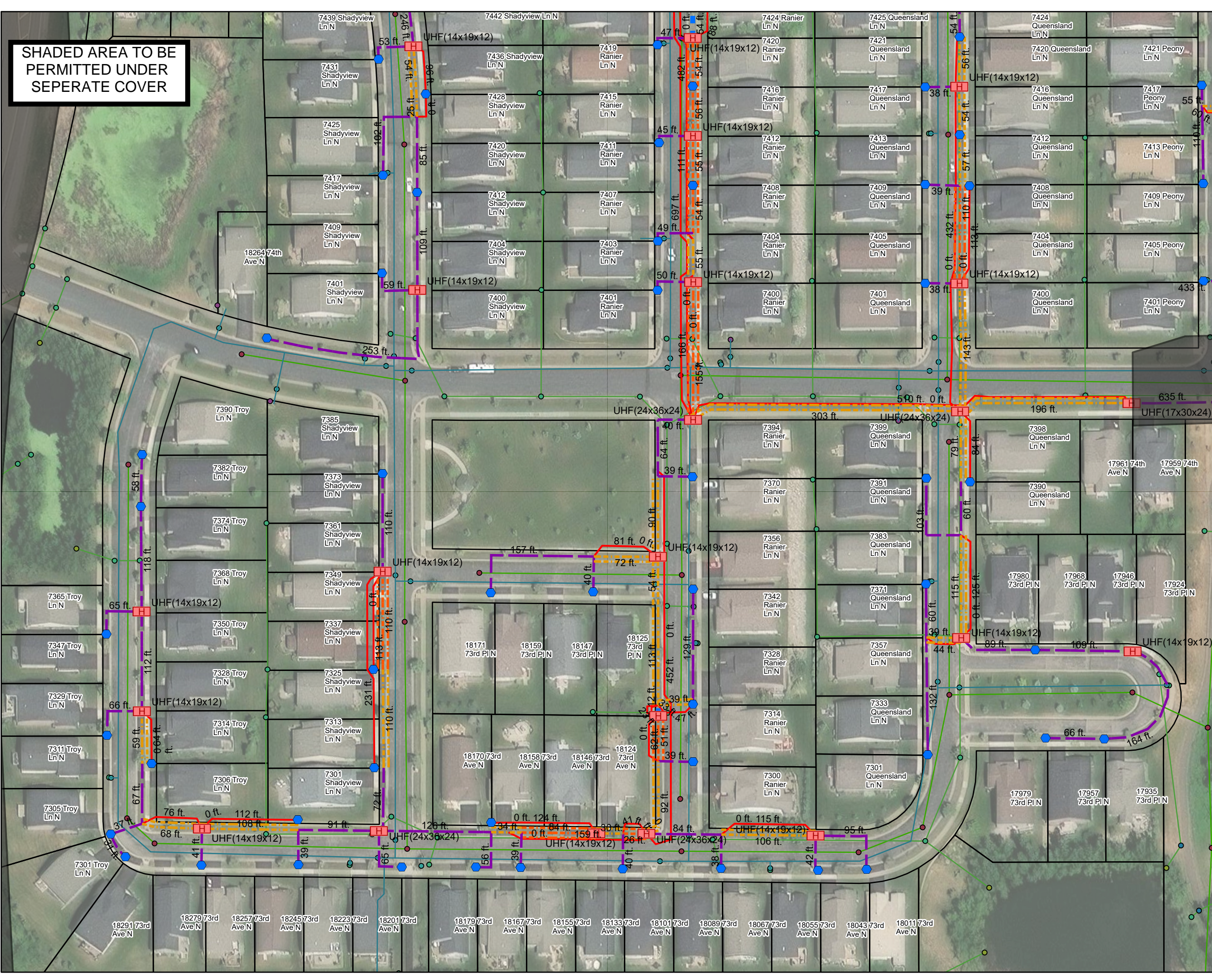
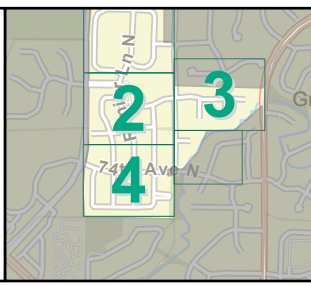

Legend

- Parcels - Hennepin County
- Civil Structures**
 - FlowerPot
 - Handhole
- Civil Pathway**
 - Proposed, BM60(1) (1.25)
 - Proposed, BM60(2) (1.25)
 - Proposed, BM60(3) (1.25)
 - Proposed, BM60(4) (1.25)
- Address - For Printing Only**
 - Address - For Printing Only
- MapleGrove Reference Duct**
 - Reference Only Duct
 - wMeter_Irrigation
- irrConduit
- irrCurbStop
- irrHandholes
- irrHeads
- irrPipes
- irrValves
- ssManhole
- ssNetworkStructure
- ssPipes
- ssPipes_Retired
- swPipes
- swManhole
- swInlet
- swControlValves
- swDrainTile
- swDrainTileStructures
- swNetworkStructure
- swOutlet
- wHydrant
- wPipes
- wSystemValve
- wControlValve

SHADED AREA TO BE PERMITTED UNDER SEPERATE COVER

Scale: 1" = 75 ft

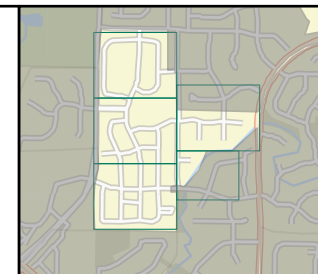

DETAILS

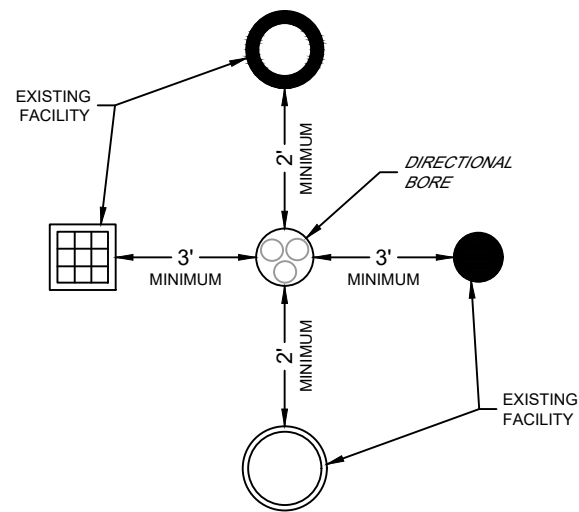

MAINTAIN A MINIMUM OF AT LEAST 3 FEET OF HORIZONTAL SEPARATION AND 2 FEET VERTICAL SEPARATION BETWEEN DIRECTIONAL BORE AND ALL EXISTING FACILITIES.

THE TARGET FOR HORIZONTAL CLEARANCE FOR SANITARY SEWER, WATER AND STORM SEWER IS 10 FEET.

UTILITY SEPARATION DETAIL

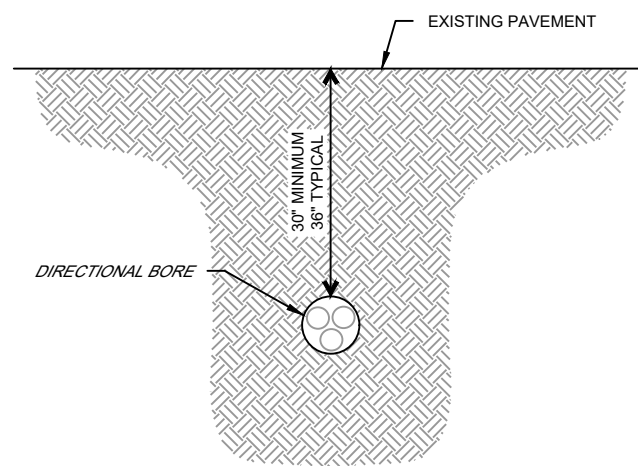

DIRECTIONAL BORING DETAIL

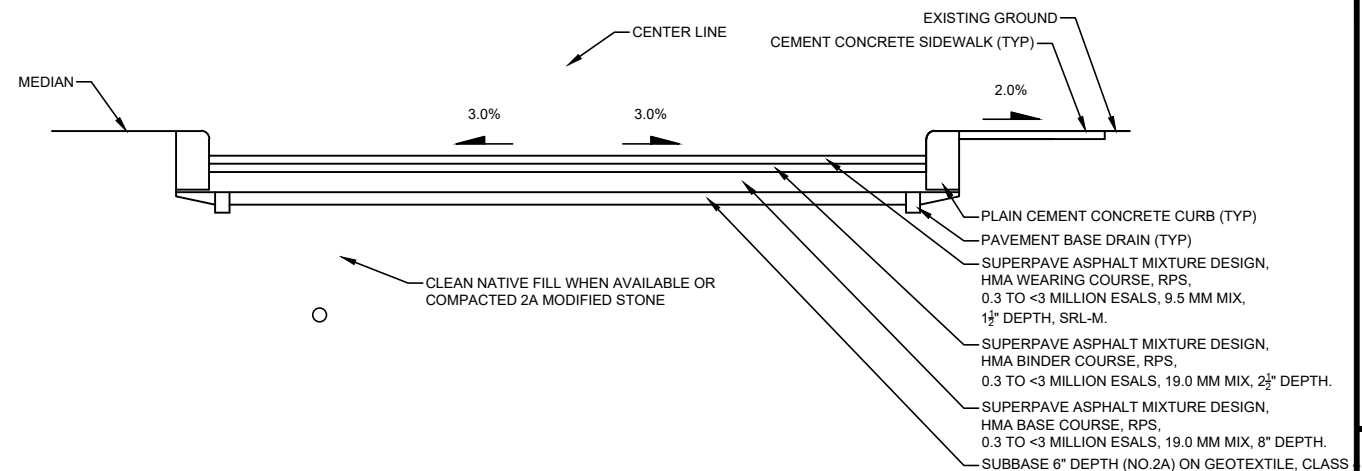

PAVEMENT RESTORATION FOR STREET UTILITY TRENCH (NOT TO SCALE)

*PAVEMENT SHALL BE REMOVED TO NEAREST CONSTRUCTION JOINT IF TRENCH EDGE IS 2' OR LESS FROM JOINT (TO BE DETERMINED BY THE ENGINEER).

- NOTES:
1. ALL TIE BARS AND DOWEL BARS ARE TO BE EPOXY COATED (INCIDENTAL).
 2. THE BASE COURSE SHALL BE 8" OR MORE INCHES. FOR CONCRETE STREETS THE CONCRETE SHALL BE BROUGHT TO GRADE (INCLUDING 1'-0" OVERLAP) AND APPROPRIATE FINISHED.
 3. ALL EXISTING PAVEMENTS SHALL BE SAW CUT 1'-0" ON EITHER SIDE OF THE TRENCH OR PAVEMENT OPENING. UNDER NO CIRCUMSTANCE, SHOULD EXISTING PAVEMENT, WHICH HAS BEEN UNDERMINED OR OTHERWISE DISTURBED, BE LEFT IN PLACE AND NOT RESTORED.

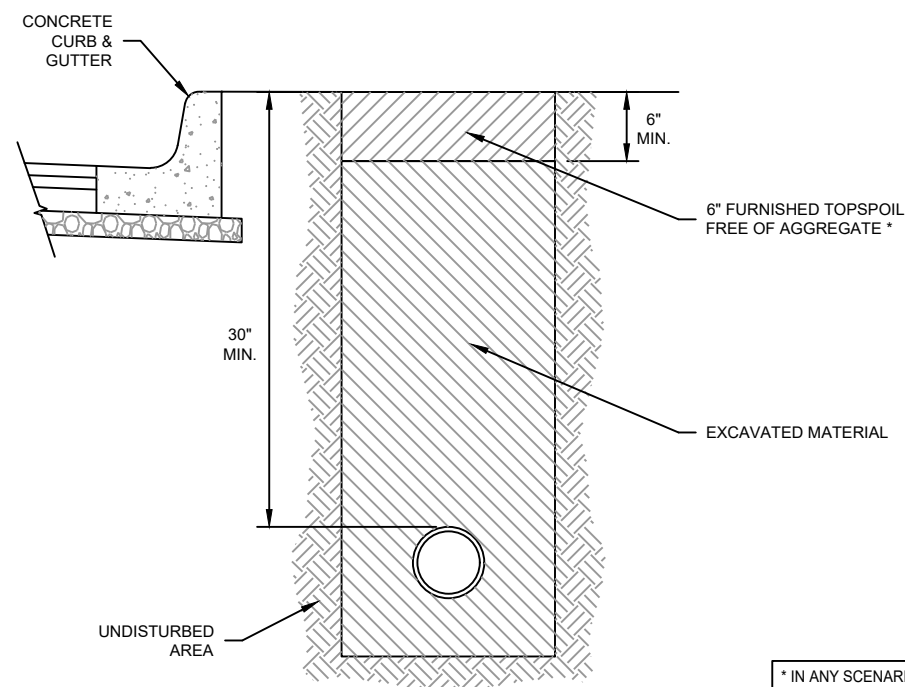

RESTORATION DETAIL

* IN ANY SCENARIO TOP 6" FREE OF AGGREGATE OR FURNISHED TOPSOIL 6"

FIBERHOOD:
MPGV-MN-1-18

ENGINEER:
hbK
UTILITY INFRASTRUCTURE SOLUTIONS ENGINEERING
A QUANTA SERVICES COMPANY
921 WEST VAN BUREN, SUITE 100
CHICAGO, IL 60607
PHONE: (312) 432-0076 FAX: (312) 432-0231
STATE OF ILLINOIS, DEPARTMENT OF PROFESSIONAL REGULATION, LICENSE NO. 184-002308

OWNER/DEVELOPER:
gatewayfiber
275 WEST SERVICE RD
SUITE O
WRIGHT CITY, MO 63390

TITLE:
PROPOSED FIBER - OPTIC INSTALLATION - CIVIL DESIGN
75TH AVE N & RANIER LN N
MAPLE GROVE, MN

REVISIONS			
REV	DATE	DESCRIPTION	BY
00	12/30/24	FOR REVIEW	EJ
01			
02			
03			
04			
05			
06			
07			
08			
09			
10			
11			

DRAWN BY: **EJ** CHECKED BY: **AJR** APPROVED BY: **NFJ**

PROJECT NUMBER: **24-0177**
DATE DRAWN: **12/30/24**

SHEET: **C1**



Pomona, California
Toll-Free: 800.735.5566
Phone: 909.634.3020
Fax: 800.827.7111

Back to Table of Contents

L Series 910

Light Duty

Flush Cover

Material: HDPE
Weight: 1.5 lbs.
Model: 910-3 No Bolt
910-3B Bolt Down

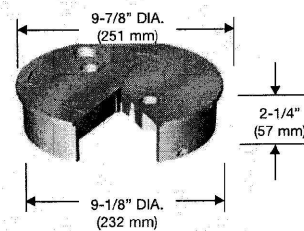
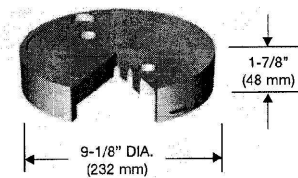

T-Cover

Material: HDPE
Weight: 1.5 lbs.
Model: 910-4 No Bolt
910-4B Bolt Down

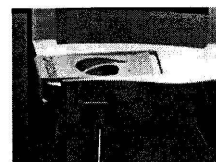

Loc-Kit™
(Patent Pending)

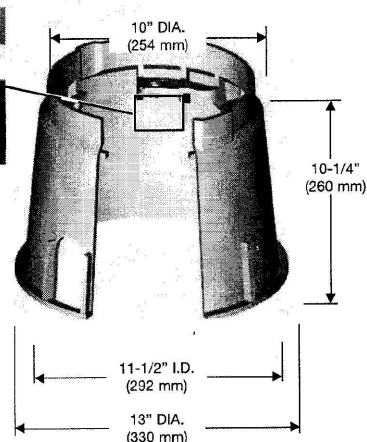

Body

Material: HDPE
Weight: 3.0 lbs.
Model: 910-10

Colors Available

Green, Grey, Black, Tan or Violet

Note: For use in non-vehicular traffic situations only. We do not recommend installation in concrete or asphalt. Weights and dimensions may vary slightly.

Revision Date 4/2003
©2008 Oldcastle Precast, Inc.



Pomona, California
Toll-Free: 800.735.5566
Phone: 909.634.3020
Fax: 800.827.7111

Back to Table of Contents

L Series 1419-12

Light Duty

Flush Cover

Material: HDPE
Weight: 3.0 lbs.
Model: 1419-3 No Bolt
1419-3B Bolt Down
See OPTION SECTION:
- Hinged Cover

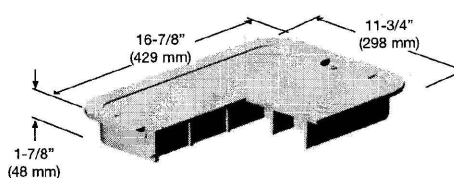
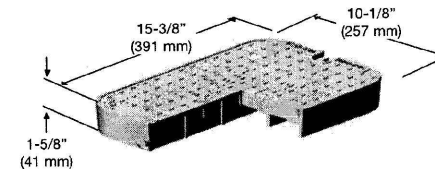

T-Cover

Material: HDPE
Weight: 3.0 lbs.
Model: 1419-4 No Bolt
1419-4B Bolt Down
See OPTION SECTION:
- Meter reader cover

Body

Material: HDPE
Weight: 7.0 lbs.
Model: 1419-12
See OPTION SECTION:
- Slots

Colors Available

Green, Gray, Black, Tan or Violet

Note: For use in non-vehicular traffic situations only. We do not recommend installation in concrete or asphalt. Weights and dimensions may vary slightly.

Revision Date 4/2003
©2008 Oldcastle Precast, Inc.

FIBERHOOD:

MPGV-MN-1-18

ENGINEER:



A QUANTA SERVICES COMPANY

921 WEST VAN BUREN, SUITE 100
CHICAGO, IL 60607
PHONE: (312) 432-0076 FAX: (312) 432-0231
STATE OF ILLINOIS, DEPARTMENT OF PROFESSIONAL
REGULATION, LICENSE NO. 184-002308

OWNER/DEVELOPER:



275 WEST SERVICE RD
SUITE O
WRIGHT CITY, MO 63390

TITLE:

PROPOSED FIBER - OPTIC
INSTALLATION - CIVIL DESIGN
75TH AVE N & RANIER LN N
MAPLE GROVE, MN

REVISIONS

REV	DATE	DESCRIPTION	BY
00	12/30/24	FOR REVIEW	EJ
01			
02			
03			
04			
05			
06			
07			
08			
09			
10			
11			

DRAWN BY: EJ
CHECKED BY: AJR
APPROVED BY: NFJ

PROJECT NUMBER: 24-0177

DATE DRAWN: 12/30/24

SHEET:

C2

DETAILS



Duralite®

1730

Material & Style

Composite
Straight Wall

1730-12

ANSI/SCTE-77, Tier 15
28.5 lbs
ANSI/SCTE-77, Tier 22
31.3 lbs

1730-18

ANSI/SCTE-77, Tier 15
36.2 lbs
ANSI/SCTE-77, Tier 22
41.3 lbs

1730-18

ANSI/SCTE-77, Tier 15
41 lbs
ANSI/SCTE-77, Tier 22
41 lbs

Options

Mouseholes/Knockouts

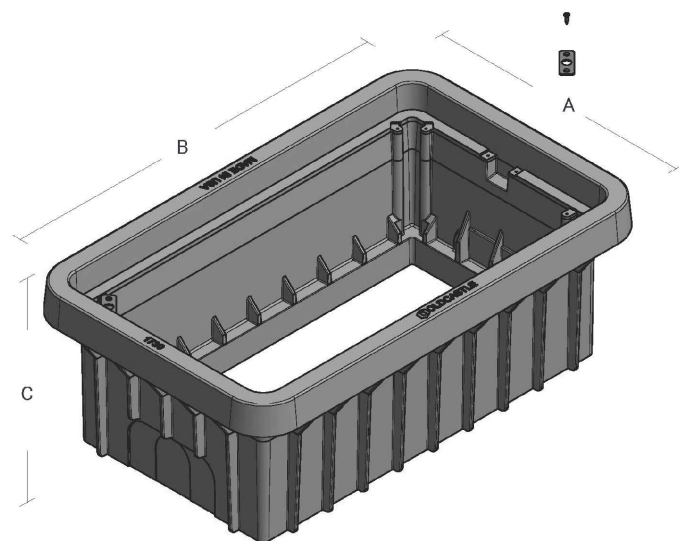

	A	B	C
1730-12	20 1/2"	33 1/2"	12"
1730-18	20 1/2"	33 1/2"	18"
1730-24	20 1/2"	33 1/2"	24"

Cover comes standard with permanent markings for manufacturer, load rating, model size and manufacturing location. Based upon lid and body combination, this unit can be Tier 15 or Tier 22. T22 rating when paired with T22 polymer concrete lid.

Revision 04/2023

oldcastleinfrastructure.com
(888) 965-3227

Trusted partnerships. Full scale solutions.

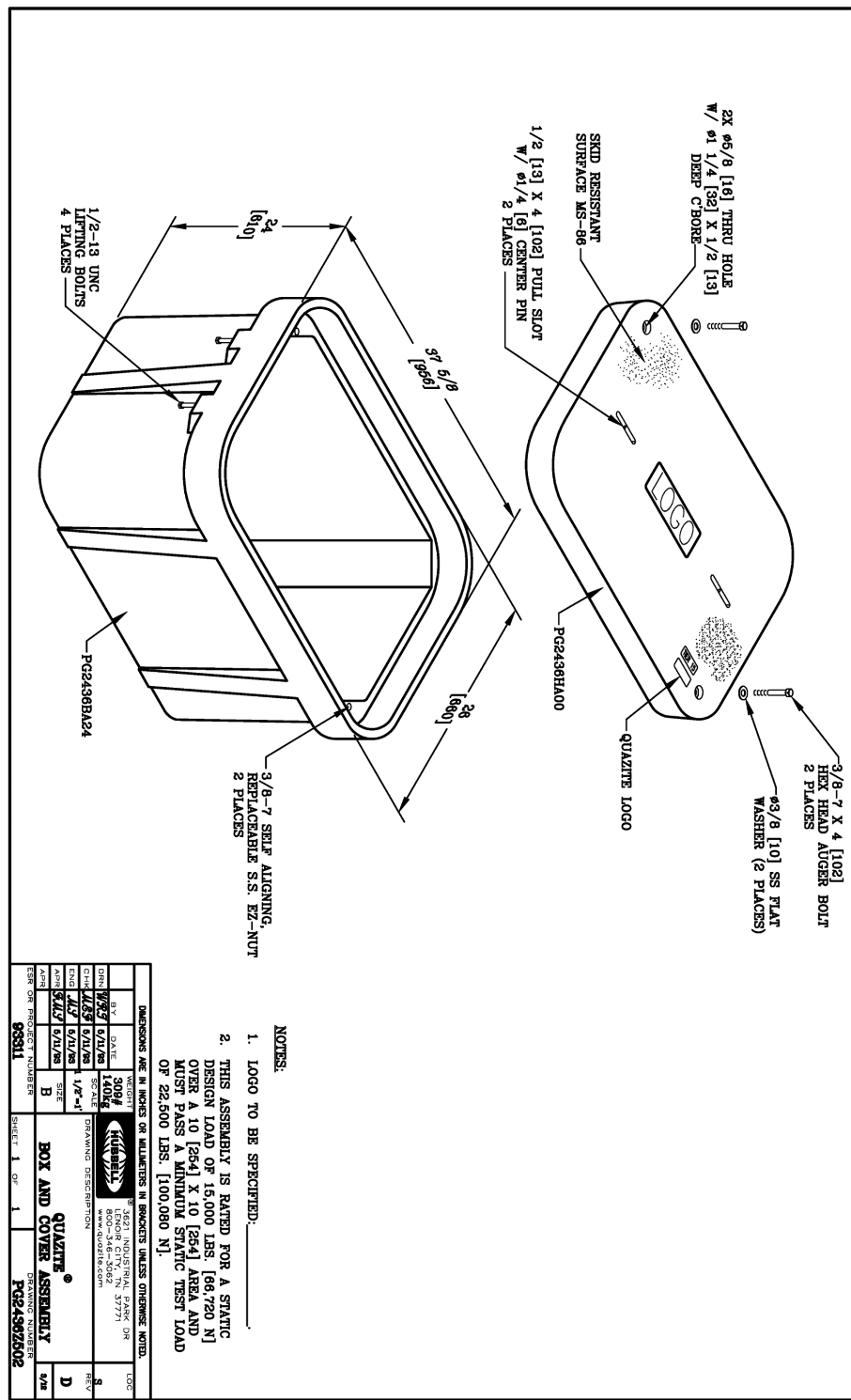

FIBERHOOD:
MPGV-MN-1-18

ENGINEER:
UTILITY INFRASTRUCTURE SOLUTIONS **hbk** ENGINEERING
A QUANTA SERVICES COMPANY
921 WEST VAN BUREN, SUITE 100
CHICAGO, IL 60607
PHONE: (312) 432-0076 FAX: (312) 432-0231
STATE OF ILLINOIS, DEPARTMENT OF PROFESSIONAL REGULATION, LICENSE NO. 184-002308

OWNER/DEVELOPER:
gatewayfiber
275 WEST SERVICE RD
SUITE O
WRIGHT CITY, MO 63390

TITLE:
PROPOSED FIBER - OPTIC
INSTALLATION - CIVIL DESIGN
75TH AVE N & RANIER LN N
MAPLE GROVE, MN

REVISIONS

REV	DATE	DESCRIPTION	BY
00	12/30/24	FOR REVIEW	EJ
01			
02			
03			
04			
05			
06			
07			
08			
09			
10			
11			

DRAWN BY: EJ
CHECKED BY: AJR
APPROVED BY: NFJ

PROJECT NUMBER: 24-0177
DATE DRAWN: 12/30/24

SHEET: C3



SPECIFICATIONS/DATA

30" x 48" PG Style (Stackable) Assembly
30" x 48" PD Style (Nestable) Assembly

Covers (Blank unless logo is specified)

DESCRIPTION	PART NO.	WEIGHT #	DESIGN/TEST LOAD	ANSI TIER
W/2 Bolts	PG3048CA00	159 (72.1 kg)	8,000 / 12,000	8
Gasketed w/2 Bolts	PG3048CG00	159 (72.1 kg)	8,000 / 12,000	8
No Bolts	PG3048WA00	159 (72.1 kg)	8,000 / 12,000	8
Heavy Duty w/2 Bolts	PG3048HA00	206 (93.4 kg)	15,000 / 22,500	15
Gasketed Heavy Duty w/2 Bolts	PG3048HG00	206 (93.4 kg)	15,000 / 22,500	15
Extra Heavy Duty w/2 Bolts	PG3048HH00	220 (99.7 kg)	22,500 / 33,750	15*
2-piece w/2 Bolts	PG3048CS00	181 (82.1 kg)	8,000 / 12,000	8
Heavy Duty 2-piece w/2 Bolts	PG3048HS00	206 (93.4 kg)	15,000 / 22,500	15
2-piece Overlapping	PG3048CC00	227 (103.0 kg)	8,000 / 12,000	8
Heavy Duty 2-piece Overlapping	PG3048HC00	234 (106.1 kg)	15,000 / 22,500	15

Covers with meter lids available upon request.
 * Gasketed covers and bolt grommets must be used with a gasketed box. Gaskets reduce the inflow of fluids but do not make the enclosure water tight.
 * Loadings for HH covers comply with all test provisions of ANSI/SCTE 77 except that the vertical design load is 22,500 lbs. with a test load of 33,750 lbs. over a 10" x 20" plate.

PG Boxes (Stackable with self-aligning, replaceable EZ-Nut) *24" & 36" deep boxes must be used as bottom of any stack

DESCRIPTION	PART NO.	WEIGHT #	DIMENSION A	DIMENSION B	DESIGN/TEST LOAD #	ANSI TIER
Open Bottom	PG3048BA18	185 (83.9 kg)	18" (457 mm)	15" (381 mm)	22,500 / 33,750	15**
	PG3048BA24	236 (107.0 kg)	24" (609 mm)	21" (533 mm)	22,500 / 33,750	15**
	PG3048BA36	343 (155.6 kg)	36" (914 mm)	33" (838 mm)	22,500 / 33,750	15**
Open Bottom w/ Gasket	PG3048BG18	185 (83.9 kg)	18" (457 mm)	15" (381 mm)	22,500 / 33,750	15**
	PG3048BG24	236 (107.0 kg)	24" (609 mm)	21" (533 mm)	22,500 / 33,750	15**
	PG3048BG36	343 (155.6 kg)	36" (914 mm)	33" (838 mm)	22,500 / 33,750	15**
Open Bottom w/ 2 Mouseholes	PG3048BB18	185 (83.9 kg)	18" (457 mm)	15" (381 mm)	22,500 / 33,750	15**
	PG3048BB24	236 (107.0 kg)	24" (610 mm)	21" (533 mm)	22,500 / 33,750	15**
	PG3048BB36 †	343 (155.6 kg)	36" (914 mm)	33" (838 mm)	22,500 / 33,750	15**
Solid Bottom	PG3048DA18	220 (99.8 kg)	18 1/2" (470 mm)	15" (381 mm)	22,500 / 33,750	15**
	PG3048DA24	287 (130.2 kg)	24 1/2" (622 mm)	21" (533 mm)	22,500 / 33,750	15**
	PG3048DA36	394 (178.7 kg)	36 1/2" (927 mm)	33" (838 mm)	22,500 / 33,750	15**
Solid Bottom w/ Gasket	PG3048DG18	220 (99.8 kg)	18 1/2" (470 mm)	15" (381 mm)	22,500 / 33,750	15**
	PG3048DG24	287 (130.2 kg)	24 1/2" (622 mm)	21" (533 mm)	22,500 / 33,750	15**
	PG3048DG36	394 (178.7 kg)	36 1/2" (927 mm)	33" (838 mm)	22,500 / 33,750	15**

† PG3048BB36 is not UL Listed.
 ** Loadings comply with ANSI/SCTE 77. These boxes meet and exceed ANSI Tier 15 test provisions.

PD Boxes (Nestable)

DESCRIPTION	PART NO.	WEIGHT #	DIMENSION C	DIMENSION D	DESIGN/TEST LOAD #	ANSI TIER
Open Bottom	PD3048BA24	286 (130 kg)	24" (610 mm)	21" (533 mm)	22,500 / 33,750	15**
	PD3048BA48	614 (278.5 kg)	48" (1219 mm)	45" (1143 mm)	22,500 / 33,750	15**
Open Bottom w/ Gasket	PD3048BG24	286 (130 kg)	24" (610 mm)	21" (533 mm)	22,500 / 33,750	15**
	PD3048BG48	614 (278.5 kg)	48" (1219 mm)	45" (1143 mm)	22,500 / 33,750	15**
Open Bottom w/ 2 Mouseholes	PD3048BB24	286 (130 kg)	24" (610 mm)	21" (533 mm)	22,500 / 33,750	15**
	PD3048BB48	614 (278.5 kg)	48" (1219 mm)	45" (1143 mm)	22,500 / 33,750	15**

** Loadings comply with ANSI/SCTE 77. These boxes meet and exceed ANSI Tier 15 test provisions.

Top Extension (For use on top of PG and PD boxes of any depth)

DESCRIPTION	PART NO.	WEIGHT #	DESIGN/TEST LOAD #	ANSI TIER
Open Bottom*	PG3048EA11	100 (45.4 kg)	22,500 / 33,750	15**

* In addition, this extension can be used as a bottom extension for 18" deep PG boxes.
 ** Loadings comply with ANSI/SCTE 77. These boxes meet and exceed ANSI Tier 15 test provisions.

Bottom Extensions (For use under 18" deep PG style box only, one per box)

DESCRIPTION	PART NO.	WEIGHT #	DIMENSION E	DIMENSION F	DESIGN/TEST LOAD #	ANSI TIER
Open Bottom	PG3048EA08	102 (46.3 kg)	8 3/4" (222 mm)	1" (25 mm)	22,500 / 33,750	15*
Solid Bottom	PG3048EA08	151 (68.0 kg)	9 1/4" (235 mm)	N/A	22,500 / 33,750	15*

* Loadings comply with ANSI/SCTE 77. These boxes meet and exceed ANSI Tier 15 test provisions.
 Dimensions & weights in parentheses are metric equivalent.



JULY 2006



SPECIFICATIONS/DATA

48" x 48" PG Style (Stackable) Assembly

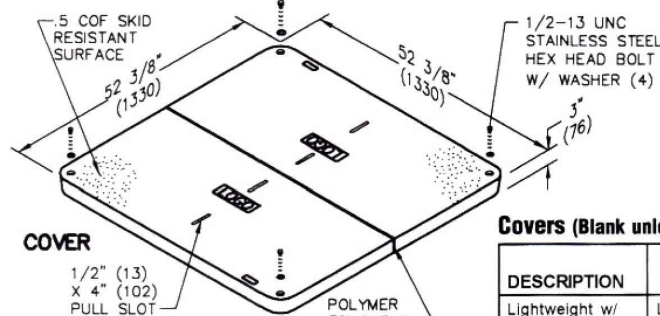

Covers (Blank unless logo is specified)

DESCRIPTION	PART NO.	WEIGHT #	DESIGN/TEST LOAD #
Lightweight w/ 4 Bolts	LG4848CA00	240 (108.9 kg)	5,000 / 7,500
Lightweight w/ No Bolts	LG4848WA00	240 (108.9 kg)	5,000 / 7,500
Heavy Duty w/ 4 Bolts *	PG4848HA00	364 (165.1 kg)	15,000 / 22,568
Extra Heavy Duty w/ 4 Bolts **	PG4848HH00	626 (284.0 kg)	22,568 / 33,852

Torsion assist covers are available. See page 44.
 * PG4848HA00 cover must be used with either PG4848BK or PG4848DK boxes.
 ** PG4848HH00 cover must be used with either PG4848BH or PG4848DH boxes.

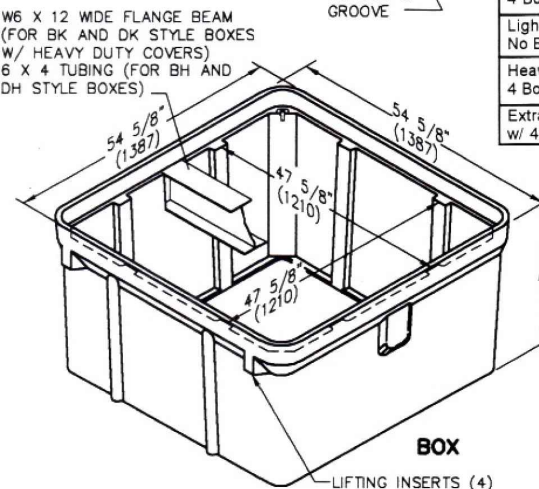

Boxes (Stackable with self-aligning, replaceable EZ-Nut)

DESCRIPTION	PART NO.	WEIGHT #	DIMENSION A	DIMENSION B	DESIGN/TEST LOAD #
Open bottom (Beam pocket but no beam provided)	PG4848BA36	588 (267.7 kg)	36" (914 mm)	33" (838 mm)	8,000 / 12,000
	PG4848BA48	763 (346.1 kg)	48" (1219 mm)	45" (1143 mm)	8,000 / 12,000
Open Bottom, Heavy Duty, w/ *	PG4848BK36	665 (301.6 kg)	36" (914 mm)	33" (838 mm)	15,000 / 22,568
W6 x 12 Wide Flange Beam *	PG4848BK48	840 (381.0 kg)	48" (1219 mm)	45" (1143 mm)	15,000 / 22,568
Open Bottom, Heavy Duty, w/ **	PG4848BH36	665 (301.6 kg)	36" (914 mm)	33" (838 mm)	22,568 / 33,852
6 x 4 Tubing **	PG4848BH48	840 (381.0 kg)	48" (1219 mm)	45" (1143 mm)	22,568 / 33,852
Solid Bottom (Beam pocket but no beam provided)	PG4848DA36	685 (310.7 kg)	36 1/2" (927 mm)	33" (838 mm)	8,000 / 12,000
	PG4848DA48	860 (390.1 kg)	48 1/2" (1232 mm)	45" (1143 mm)	8,000 / 12,000
Solid Bottom, Heavy Duty, w/ *	PG4848DK36	762 (345.6 kg)	36 1/2" (927 mm)	33" (838 mm)	15,000 / 22,568
W6 x 12 Wide Flange Beam *	PG4848DK48	937 (425.0 kg)	48 1/2" (1232 mm)	45" (1143 mm)	15,000 / 22,568
Solid Bottom, Heavy Duty, w/ **	PG4848DH36	762 (345.6 kg)	36 1/2" (927 mm)	33" (838 mm)	22,568 / 33,852
6 x 4 Tubing **	PG4848DH48	937 (425.0 kg)	48 1/2" (1232 mm)	45" (1143 mm)	22,568 / 33,852

Dimensions & weights in parentheses are metric equivalent.

STRONGWELL 3621 Industrial Park Drive • Lenoir City, TN 37771 (800) 346-3062 • (865) 986-9726 • FAX (865) 986-0585

FIBERHOOD:
MPGV-MN-1-18

ENGINEER:
hbk
 A QUANTA SERVICES COMPANY
 921 WEST VAN BUREN, SUITE 100
 CHICAGO, IL 60607
 PHONE: (312) 432-0076 FAX: (312) 432-0231
 STATE OF ILLINOIS, DEPARTMENT OF PROFESSIONAL REGULATION, LICENSE NO. 184-002308

OWNER/DEVELOPER:
gatewayfiber
 275 WEST SERVICE RD
 SUITE O
 WRIGHT CITY, MO 63390

TITLE:
**PROPOSED FIBER - OPTIC
 INSTALLATION - CIVIL DESIGN
 75TH AVE N & RANIER LN N
 MAPLE GROVE, MN**

REVISIONS			
REV	DATE	DESCRIPTION	BY
00	12/30/24	FOR REVIEW	EJ
01			
02			
03			
04			
05			
06			
07			
08			
09			
10			
11			

DRAWN BY:	CHECKED BY:	APPROVED BY:
EJ	AJR	NFJ

PROJECT NUMBER: **24-0177**
 DATE DRAWN: **12/30/24**

SHEET:
C4

L Series 910

Light Duty

Static Vertical Load Rating (Design Load, Test Load)

- ASTM C857 - A-0.3, 300 lbf/ft², Report Ultimate
- SCTE - Light Duty, Pedestrian, 3,000 lbf

Shipping Configuration

- Unit, 99 assemblies, = 42.25 cu. ft., 395.0 lbs.

Note: For use in non-vehicular traffic situations only. We do not recommend installation in concrete or asphalt. Weights and dimensions may vary slightly.

Shipping Information

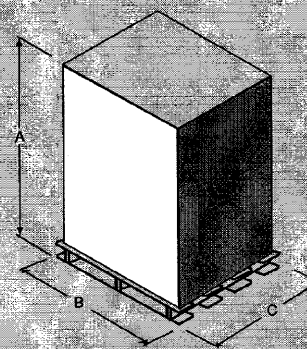

©2006 Oldcastle Precast, Inc.

[Back to Table of Contents](#)



Pomona, California
Toll-Free: 800.735.5566
Phone: 909.634.3020
Fax: 800.827.7111

Material Property	ASTM Test Method	Typical Value ¹
Type, Class, Category	D 1248	III, A, 3
Density, g/cm ³	D 1505	0.950 min., not to exceed 0.965
Tensile Strength, at break, psi	D 638	3,000 to 4,400
Elongation, at break, %	D 638	400
Tensile Impact, ft-lb/in ²	D 1822	27
Flexural Modulus, psi	D 790	120,000 min., not to exceed 240,000
Low Temperature Brittleness, F50, at °C	D 746	<-76
Hardness, Shore D	D 2240	66
Deflection Temperature, at 66 psi, °F	D 648	150° min., not to exceed 200°
Electrical Dielectric Strength, V/mil	D 149	400 min., not to exceed 600
Molded Product²		
Chemical Resistance	D 543	Very Resistant
Water Absorption	D 570	Less than 1% weight change

¹The values listed for physical property measurements are nominal values only. Certain physical property measurements are subject to variations consistent with the test methods and are within a generally accepted range for such values.
²Test reports available on request.

Dim.	Description	Value
A	Height	49"
B	Length	45"
C	Width	38"

Units: 99 per pallet
Weight: 486 lbs. per pallet

All information contained in this brochure was current at the time of printing. Because of Oldcastle Precast's policy of ongoing research and development, the Company reserves the right to discontinue or update product information without notice.

FIBERHOOD:
MPGV-MN-1-18

ENGINEER:
hbK
UTILITY INFRASTRUCTURE SOLUTIONS ENGINEERING
A QUANTA SERVICES COMPANY
921 WEST VAN BUREN, SUITE 100
CHICAGO, IL 60607
PHONE: (312) 432-0076 FAX: (312) 432-0231
STATE OF ILLINOIS, DEPARTMENT OF PROFESSIONAL REGULATION, LICENSE NO. 184-002308

OWNER/DEVELOPER:
gatewayfiber
275 WEST SERVICE RD
SUITE O
WRIGHT CITY, MO 63390

TITLE:
**PROPOSED FIBER - OPTIC
INSTALLATION - CIVIL DESIGN
75TH AVE N & RANIER LN N
MAPLE GROVE, MN**

REVISIONS			
REV	DATE	DESCRIPTION	BY
00	12/30/24	FOR REVIEW	EJ
01			
02			
03			
04			
05			
06			
07			
08			
09			
10			
11			

DRAWN BY:	CHECKED BY:	APPROVED BY:
EJ	AJR	NFJ

PROJECT NUMBER: **24-0177**
DATE DRAWN: **12/30/24**

SHEET:
C5